

MoBoアクセサリ MoBo Accessories

MoBo

アクセサリ / Accessories

●特長 / Features

- モータ直結型ボールねじの取付け用パーツを標準在庫として保有しています。
- モータ側サポートプレート（Aタイプ、Bタイプ）と支持側ブラケット、支持側専用サポートユニット、及びナットブロックを取り揃えています。
- Assembling parts of "MoBo series", Direct Motor Drive Ball Screws / Lead Screws series are set up as standard stock.
- Accessories consists of Motor side supporting plate (A-type, B-type), Supported side Bracket or Exclusive Support Unit, and Nut Block.

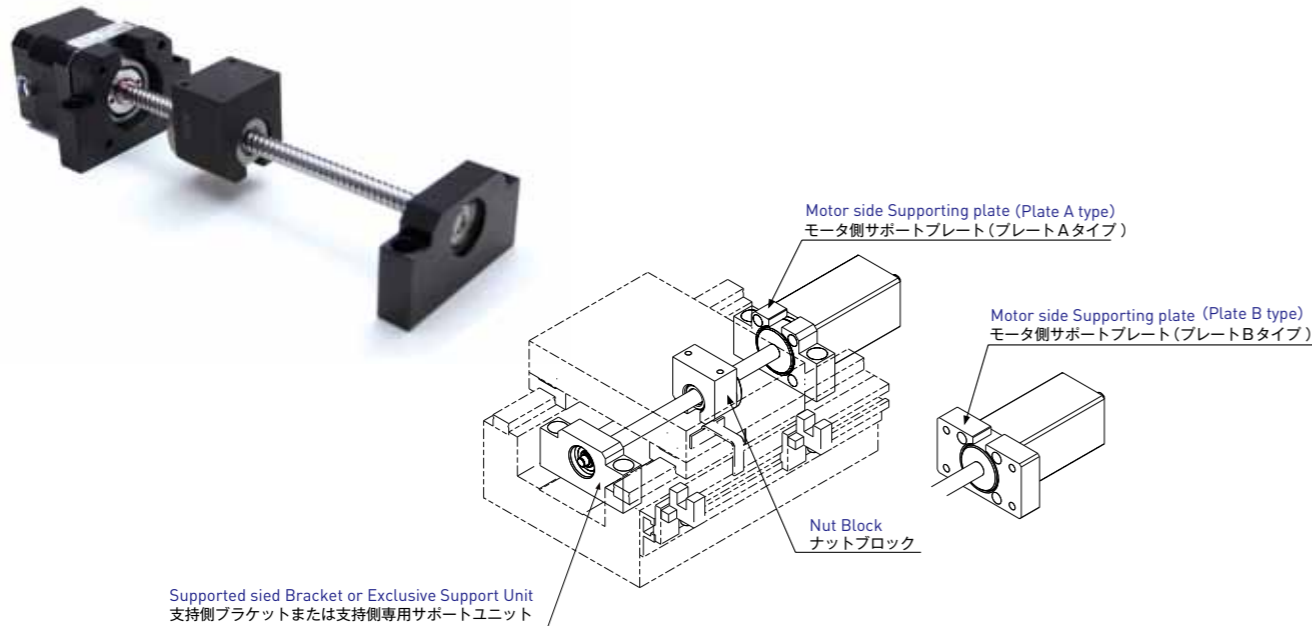

詳細寸法については、アクセサリ寸法表をご参照ください。
Please refer to Accessories dimension table for more detail.

モータ側サポートプレート A タイプ Motor side Supporting plate A type

【MP-20A】

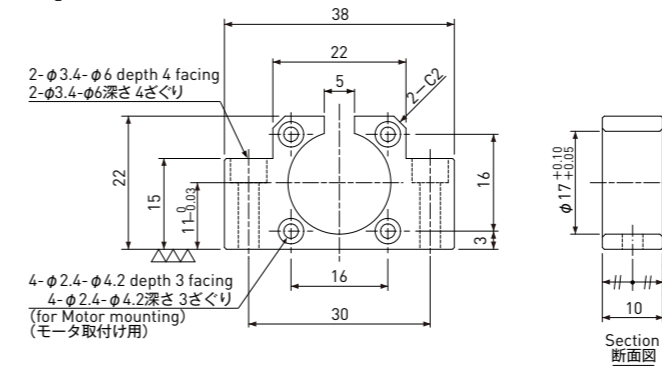

Material 材質	Aluminum alloy A5052 アルミ A5052
Surface coating 表面処理	Black anodizing 黒色アルマイト

注) モータ側サポートプレートはボールねじがストローク全域にわたってなめらかな動きになるように調整し、固定してください。

Note) Motor side Supporting plate should be fixed after adjusting to ensure smooth movement over entire travel.

【MP-24A】

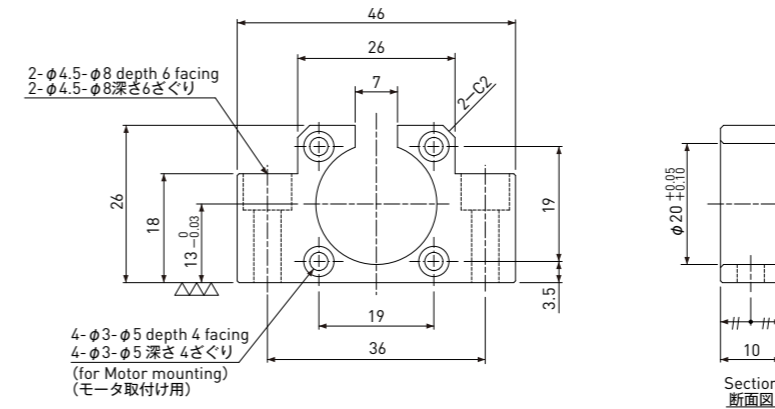

【MP-42A】

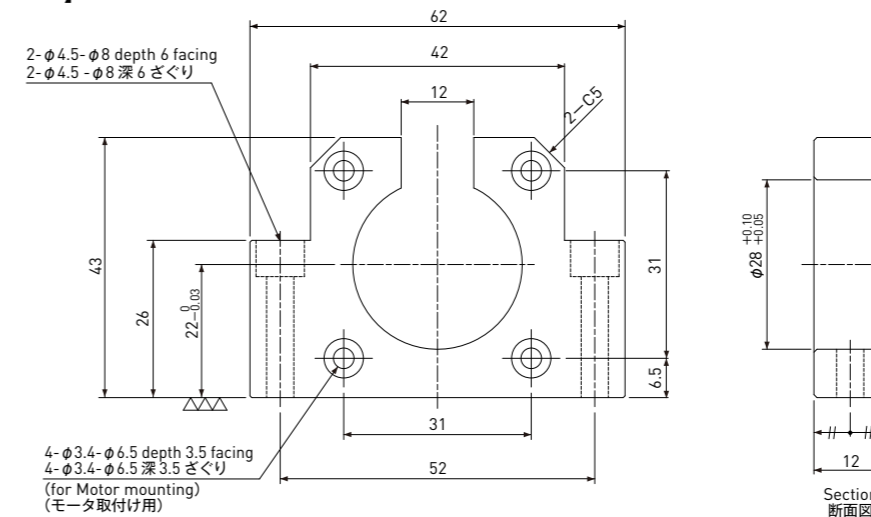

●適用モデル/ Applicable Model

**モータ側サポートプレートAタイプが使用可能なMoBoシリーズ一覧
**Applicable MoBo series for Motor side supporting plate A type

Model 型式	Applicable MoBo series / 対象シリーズ				
	Precision (MB) 精密 (MB)	Rolled (TMB) 転造 (TMB)	2-phase Rolled (2TMB) 2相転造 (2TMB)	Resin (RM) レジン (RM)	Hybrid (SiMB) ハイブリッド (Si-MB)
MP-20A	MB04005A MB0401A				SiMB0401
MP-24A	MB0401 MB06xx	TMB0401 TMB0504 TMB06xx			
MP-42A	MB08xx MB10xx	TMB08xx	2TMB08xx	RM08xx RM10xx	SiMB08xx

モータ側サポートプレート Bタイプ Motor side Supporting plate B type

[MP-20B]

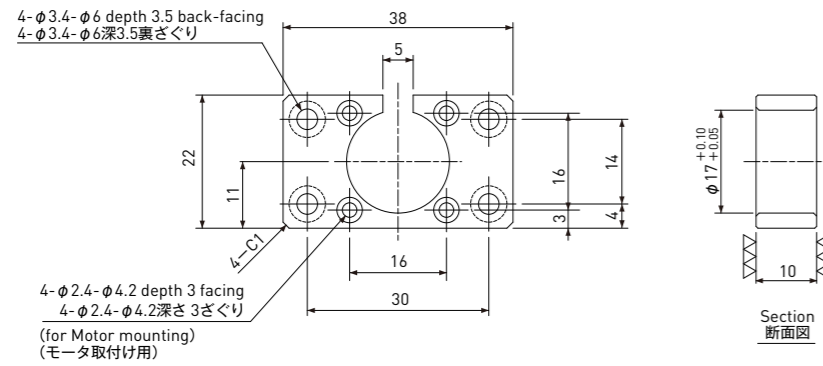

Material 材質	Aluminum alloy A5052 アルミ A5052
Surface coating 表面処理	Black anodizing 黒色アルマイト

注) モータ側サポートプレートはボールねじがストローク全域にわたってなめらかな動きになるように調整し、固定してください。

Note) Motor side Supporting plate should be fixed after adjusting to ensure smooth movement over entire travel.

[MP-24B]

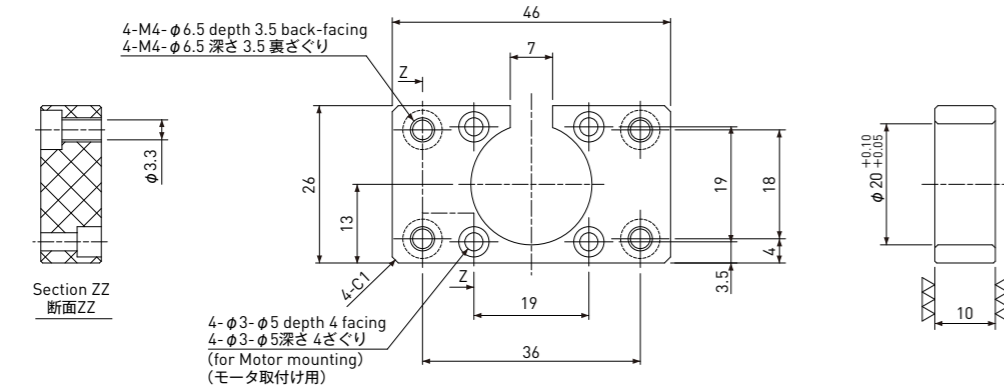

[MP-42B]

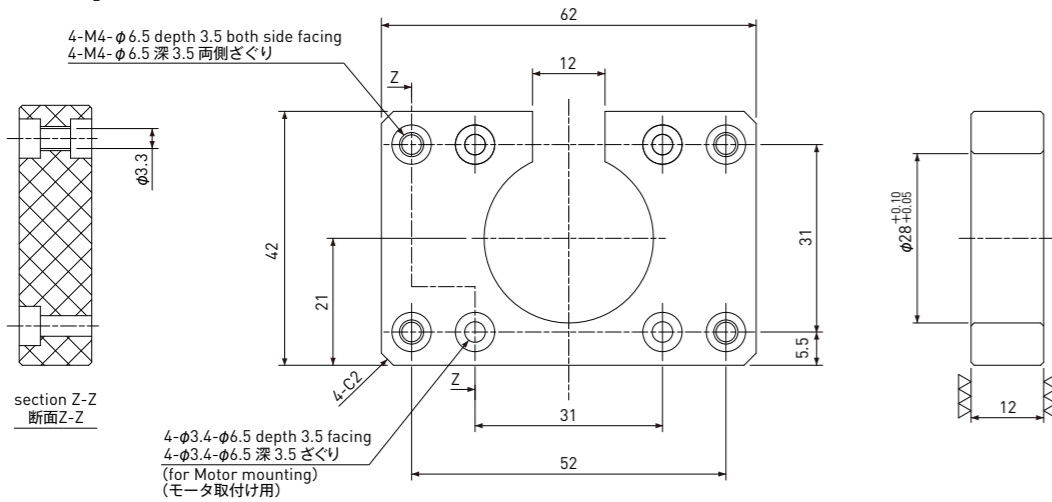

● 適用モデル/ Applicable Model

**モータ側サポートプレートBタイプが使用可能なMoBoシリーズ一覧
**Applicable MoBo series for Motor side supporting plate B type

Model 型式	Applicable MoBo series / 対象シリーズ				
	Precision (MB) 精密 (MB)	Rolled (TMB) 転造 (TMB)	2-phase Rolled (2TMB) 2相転造 (2TMB)	Resin (RM) レジン (RM)	Hybrid (SiMB) ハイブリッド (Si-MB)
MP-20B	MB04005A MB0401A				SiMB0401
MP-24B	MB0401 MB06xx	TMB0401 TMB0504 TMB06xx			
MP-42B	MB08xx MB10xx	TMB08xx	2TMB08xx	RM08xx RM10xx	SiMB08xx

支持側ブラケット / 支持側専用サポート Supported side Bracket or Exclusive Support Unit

[SP-24]

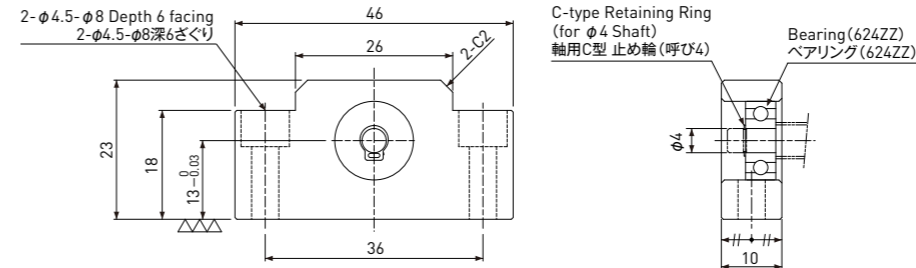

Material 材質	Aluminum alloy A5052 アルミ A5052
Surface coating 表面処理	Black anodizing 黒色アルマイト

[SP-24A]

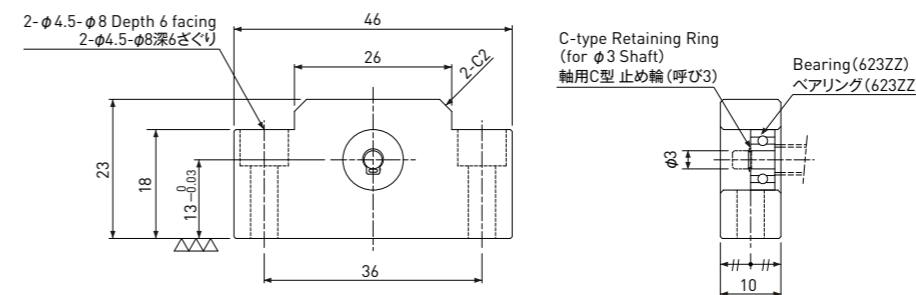

[SP-42]

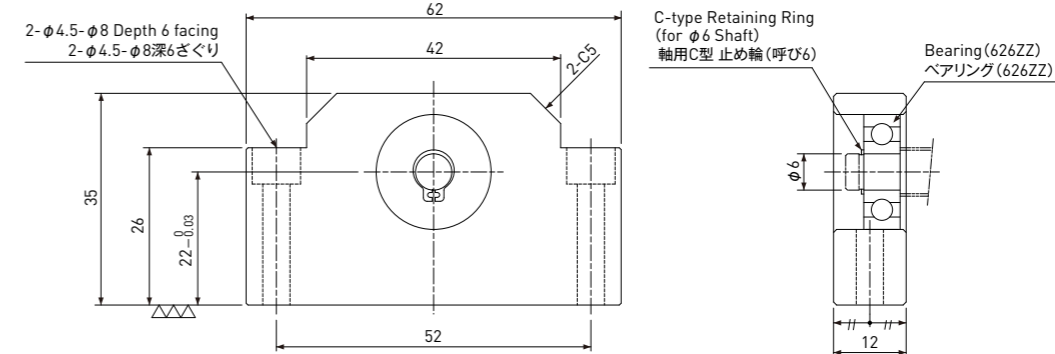

[SP-42S]

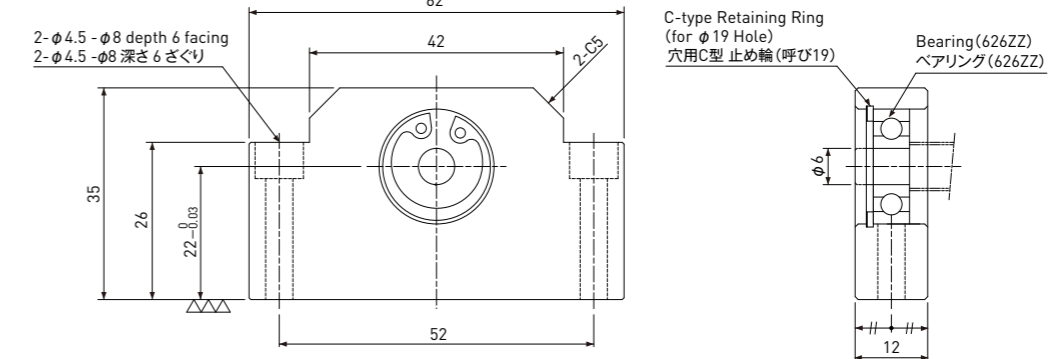

● 適用モデル/ Applicable Model

**支持側ブラケット / 支持側サポートユニットが使用可能なMoBoシリーズ一覧
**Applicable MoBo series for Supported side Bracket or Exclusive Support Unit.

Model 型式	Applicable MoBo series / 対象シリーズ				
	Precision (MB) 精密 (MB)	Rolled (TMB) 転造 (TMB)	2-phase Rolled (2TMB) 2相転造 (2TMB)	Resin (RM) レジン (RM)	Hybrid (SiMB) ハイブリッド (Si-MB)
SP-24	MB06xx	TMB06xx			
SP-24A		TMB0504			
SP-42	MB08xx MB10xx	TMB08xx		RM08xx RM10xx	SiMB08xx
SP-42S			2TMB08xx		

ナットブロック 2つ穴タイプ Nut Block with 2 holes

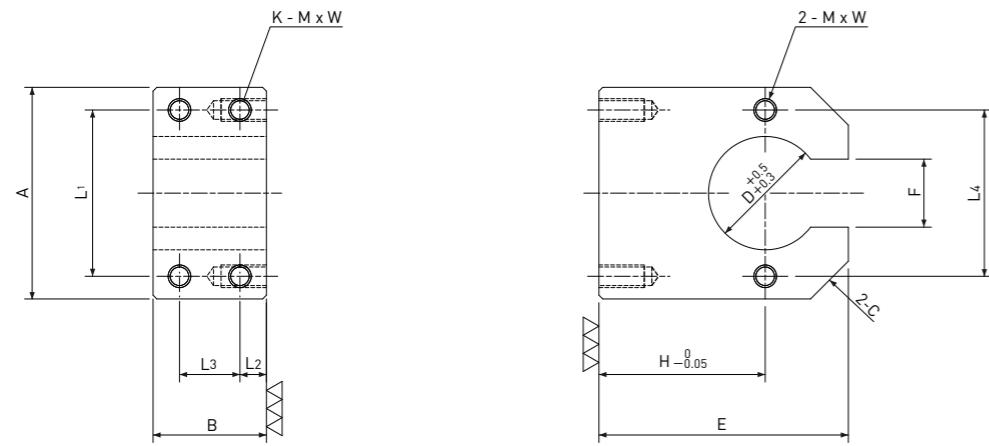

Material 材質	Aluminum alloy A5052 アルミ A5052
Surface coating 表面処理	Black anodizing 黒色アルマイト

【寸法表】

Model 型式	A	B	E	F	D	H	L ₁	L ₂	L ₃	K	MxW	C
NB-04005	20	11	18	5	10	12	14	5.5	-	2	M2.6x6	2
NB-0401A	19	11	18	5	9	12	14	5.5	-	2	M2.6x6	2
NB-0401	19	11	22	5	9	14	14	5.5	-	2	M2.6x6	4
NB-0601	23	12	23	7	11	14	17	6	-	2	M3x6	5
NB-0602	28	14	25	7	15	14	22	3	8	4	M3x6	5
NB-0801	26	12	32	9	13	22	20	6	-	2	M3x6	5
NB-0802	28	15	33	9	15	22	22	3.5	8	4	M3x6	5
NB-0805	31	25	34	9	18	22	25	4	17	4	M3x6	5
NB-1002	34	15	34	12	17	22	26	7.5	-	2	M4x8	5
NB-1004	41	24	37	12	24	22	32	5	14	4	M4x8	6

● 適用モデル/ Applicable Model

**ナットブロック(2つ穴タイプ)が使用可能なMoBoシリーズ一覧
**Applicable MoBo series for Nut Block with 2 hole type.

Model 型式	Applicable MoBo series / 対象シリーズ				
	Precision (MB) 精密 (MB)	Rolled (TMB) 転造 (TMB)	2-phase Rolled (2TMB) 2相転造 (2TMB)	Resin (RM) レジン (RM)	Hybrid (SiMB) ハイブリッド (Si-MB)
NB-04005	MB04005A				
NB-0401A	MB0401A				
NB-0401	MB0401				SiMB0401
NB-0601	MB0601				
NB-0602	MB0602				
NB-0801	MB0801				SiMB0801
NB-0802	MB0802				SiMB0802
NB-0805					SiMB0805
NB-1002	MB1002				
NB-1004	MB1004				

ナットブロック 4つ穴タイプ Nut Block with 4 holes

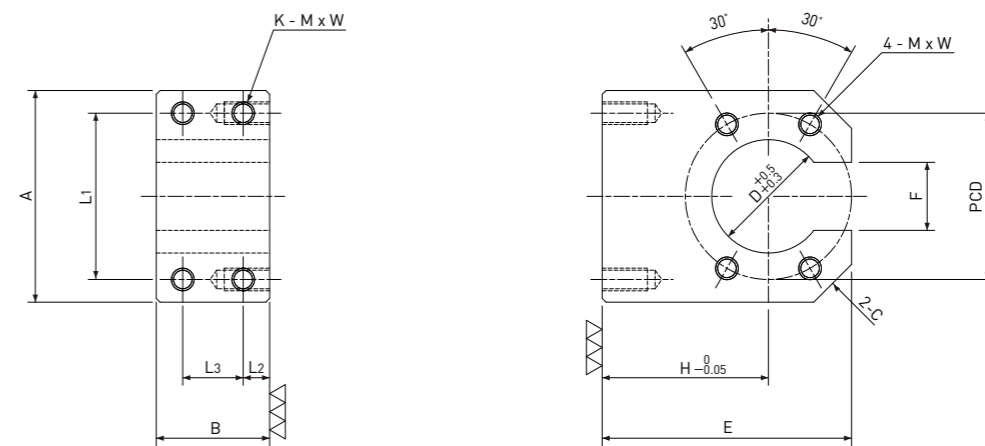

Material 材質	Aluminum alloy A5052 アルミ A5052
Surface coating 表面処理	Black anodizing 黒色アルマイト

【寸法表】

Model 型式	A	B	E	F	D	H	L ₁	L ₂	L ₃	PCD	K	MxW	C
NB-0401R	23	14	23	5	11	14	17	7	-	17	2	M3x6	4
NB-0504R	24	19	23	6	12	14	18	4	11	18	4	M3x6	4
NB-0601R	26	14	24	7	13	14	20	7	-	20	2	M3x6	4
NB-0602R	28	14	25	7	15	14	22	7	-	22	2	M3x6	4
NB-0606R	27	9	24	7	14	14	21	4.5	-	21	2	M3x6	4
NB-0801R	29	14	33	9	16	22	23	7	-	23	2	M3x6	4
NB-0802R	37	20	35	9	20	22	29	5	10	29	4	M4x8	5
NB-0805R	31	25	34	9	18	22	25	4	17	25	4	M3x6	5
NB-0812R	31	18	34	9	18	22	25	4	10	25	4	M3x6	5

● 適用モデル/ Applicable Model

**ナットブロック(4つ穴タイプ)が使用可能なMoBoシリーズ一覧
**Applicable MoBo series for Nut Block with 4 hole type.

Model 型式	Applicable MoBo series / 対象シリーズ				
	Precision (MB) 精密 (MB)	Rolled (TMB) 転造 (TMB)	2-phase Rolled (2TMB) 2相転造 (2TMB)	Resin (RM) レジン (RM)	Hybrid (SiMB) ハイブリッド (Si-MB)
NB-0401R		TMB0401			
NB-0504R		TMB0504			
NB-0601R		TMB0601			
NB-0602R		TMB0602			
NB-0606R		TMB0606			
NB-0801R		TMB0801	2TMB0801		
NB-0802R		TMB0802	2TMB0802		
NB-0805R		TMB0805	2TMB0805		
NB-0812R		TMB0812	2TMB0812		SiMB0812